

Multi Digital Temp. Controller (FX3Q SERIES)

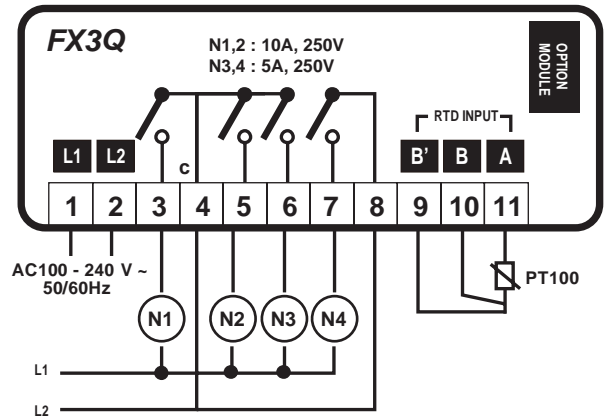

Connection Diagram



- N1 : Cooling/Heating #1 ON/OFF output, Alarm output
- N2 : Cooling/Heating #2 ON/OFF output, Alarm output
- N3 : Cooling/Heating #3 ON/OFF output, Alarm output
- N4 : Cooling/Heating #4 ON/OFF output, Alarm output

Option

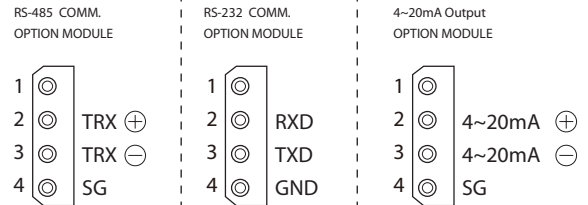

PreCaution for Use

1. This product may cause an electric shock in handling. Please do not attempt to open it with power turned on.
 2. This product should be installed in a place fixed secured by a rack or panel.
 3. This product can be used under the following environmental condition
 - ① Indoor ② Pollution Degree 2 ③ At an altitude of 2000m or below ④ Installation Category II
 4. To turn on or turn off power supply for this product, please the circuit breaker or switch of a standard product of IEC 60947-1 or IEC 60947-3 product and install it within a close distance allowing convenient operation by user.
 5. Please be understood that if this product is dismantled or modified discretionary, after sales service will not be able to be provided.
 6. An output wire to be used for this product should be inflammable grade FV1 (V-1 grade or above), the thickness of the wire should be AWG No. 20 or above, (0.50mm²)
 7. In order to prevent it from an inductive noise, please maintain the high-voltage wire and power wire separated.
 8. Please avoid installing the product in a place where a strong magnetism, noise, severe vibration and impact exist.
 9. When extending the sensor wire, use a shield wire and do not extend it unnecessary long.
 10. The sensor wire and signal wire should be away from the power and load wires using conduits separately installed.
 11. Please avoid using the product near a device generating strong high frequency noise (high-frequency welding machine, high-frequency sewing machine, high-frequency radiotelegraph, high capacity SCR controller)
 12. PRODUCT'S DAMAGES OTHER THAN THOSE DESCRIBED IN THE GUARANTEE CONDITIONS PROVIDED BY THE MANUFACTURER SHALL NOT BE RESPONSIBLE BY US.
- ※ The Aforementioned precautions must be observed, and if you fail to do so, it may cause a product's breakdown.

Basic Specification

Model	FX3Q-RTD
Power	AC100 - 240V~, 50/60Hz
Current	MAX 4VA
Connector	Screw Bolt Connector (1.5mm ² Wire Use Possibility)
Input / Output	Relay output 4p (N1,2 : 250Vac/10A, N3,4 : 250Vac/5A) RTD (PT100) temp. sensor input 1p
Operation	Temp. -10~50°C (No condensation only)
Storage	Temp. -20~60°C, Humidity Under 90%RH
Sensor	PT100 3(2) (Wire measuring range : -200 ~ 800°C, Accuracy : ±0.3°C)
Display Range	-19.9~99.9°C : unit of 0.1°C / Other range : unit of 1°C

Constitution (Function of Display Ramp and Button)

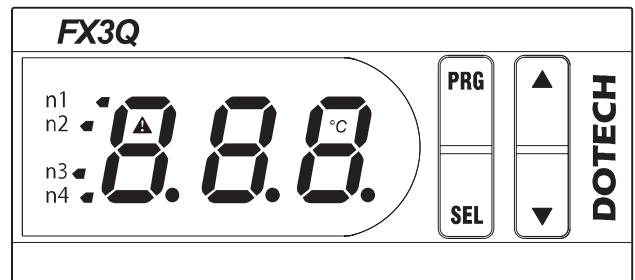

n1	Turn on when output #1 is ON (Flickering at standby)
n2	Turn on when output #2 is ON (Flickering at standby)
n3	Turn on when output #3 is ON (Flickering at standby)
n4	Turn on when output #4 is ON (Flickering at standby)
°C	Display temp. value
▲	ON at trip, Flickering at alarm

PRG	Use at program setup
SEL	Execute selected menu or Input setup value
▲	Move between menus & Increase setup value
▼	Move between menus & Decrease setup value

※ If pushing ▲, ▼ at the same time, it displays the 1st decimal place for the current temp.

Order Information

- FX3Q-RTD-00 : Basic Model
- FX3Q-RTD-R4 : RS-485 Comm. model (Comm. function MODBUS RTU MODE) ※
- FX3Q-RTD-R2 : RS-232 Comm. model (Install log printer, Trans text message) ※
- FX3Q-RTD-A1 : 4~20mA Trans output model ※

※ Comm. cable is provided basically

Dimensions and Panel Cut-Out Form

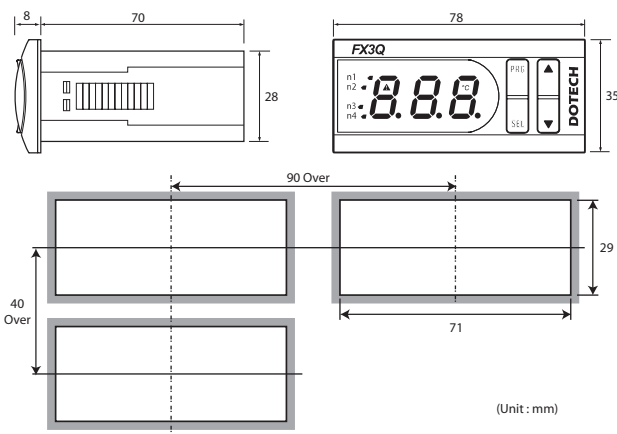

Temperature Setting Group

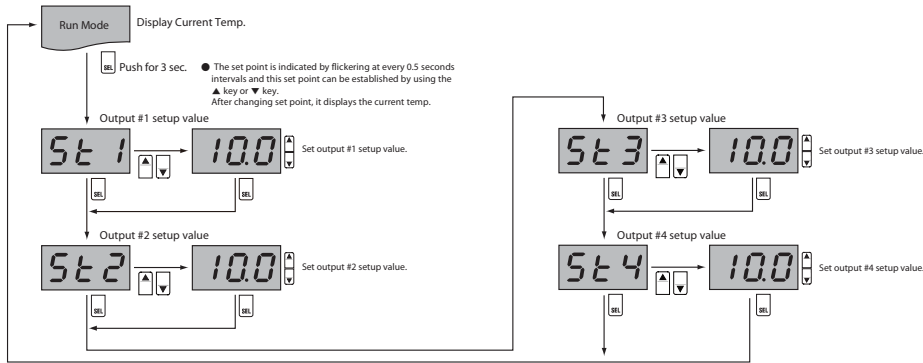

- If there's no input made for a period of 60 seconds during the setting, then it returns back to the run mode automatically.

Setting 1 Group

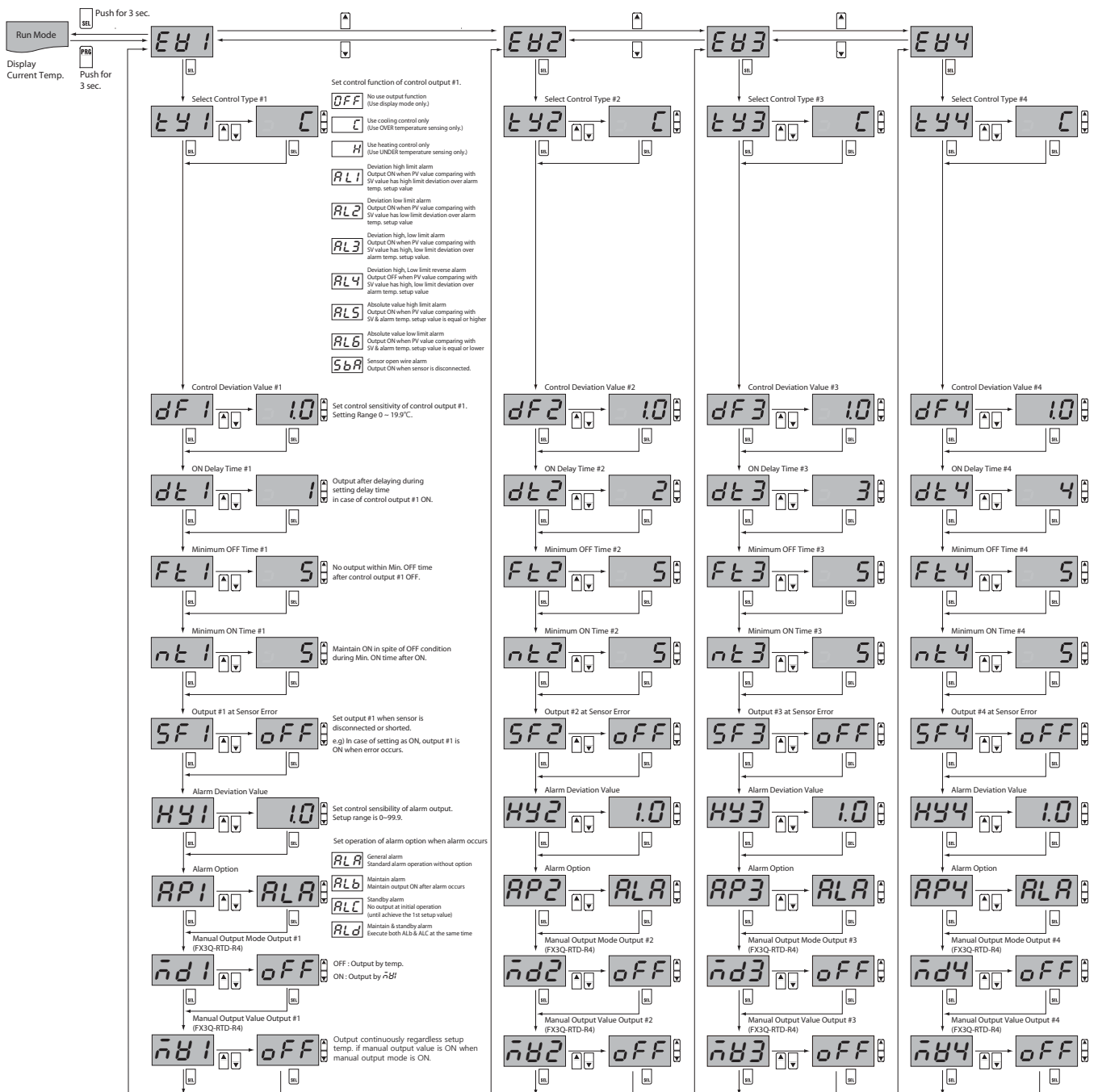

Setting 2 Group

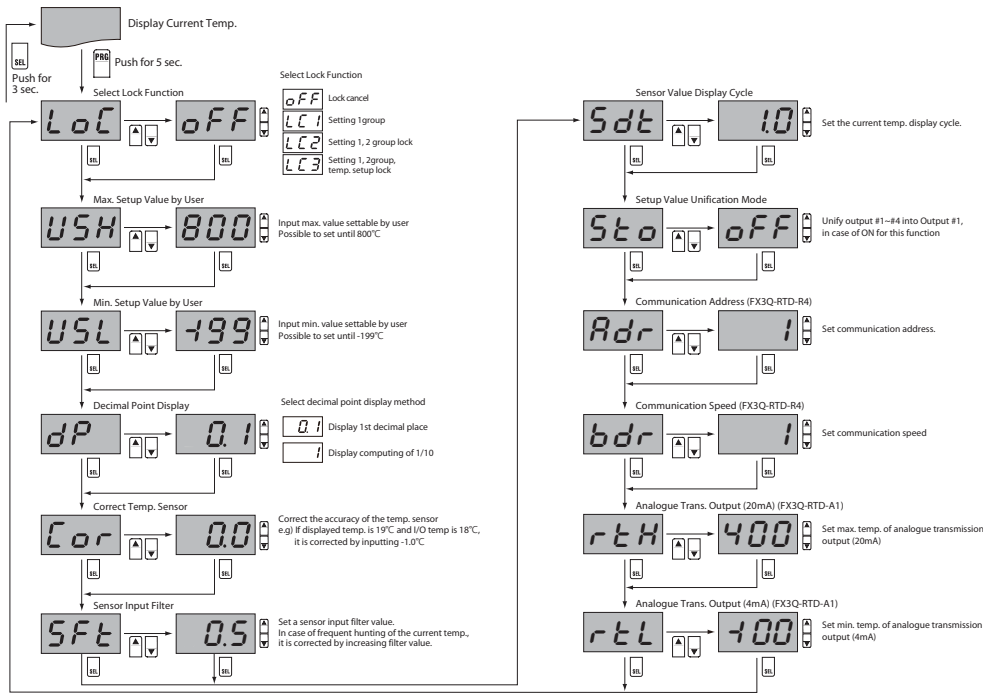

Setting 1 Group Table

NO	DESCRIPTION	CODE	UNIT	STEP	MIN	MAX	DEFAULT	USER SETUP
100	Select Control Type	ty1~4			OFF: No use C: Cooling mode H: Heating mode	SbA: Sensor open wire alarm	C	
101	Control Deviation Value	df1~4	K	0.1	0.1	99.9	1.0	
104	ON Delay Time (※1)	dt1~4	Sec.	1	0	999	1	
105	Minimum OFF Time (※2)	ft1~4	Sec.	1	0	999	5	
106	Minimum ON Time (※3)	nt1~4	Sec.	1	0	999	5	
107	Output at Sensor Error (※4)	SF1~4			OFF / On		OFF	
108	Manual Output Mode Output (※5)	nd1~4			OFF / On		OFF	
109	Manual Output Value Output (※6)	nb1~4			OFF / On		OFF	
110	Alarm Deviation Value	Hy1~4	K	0.1	0	99.9	1.0	
111	Alarm Option	AP1~4			ALA: General alarm ALb: Maintain alarm ALc: Standby alarm ALd: Maintain & standby alarm		ALA	

- ※1) ON delay time: It outputs after setting delay time in spite of output condition. During ON delay time, output lamp is turned on with output after flickering in fast cycle
- ※2) Min OFF Time: It lets output not occur within min. OFF time after it is turned off. During min. OFF time, output lamp is turned on with output after it flickers every 1 second intervals.
- ※3) Min ON Time: It is for avoiding frequent ON/OFF of control output and maintains ON condition in spite of OFF condition during Min ON Time after being turned on. (In case of sensor error, OFF at once)
- ※4) Output at Sensor Error: In case of sensor error such as open wire/short, it sets ON/OFF status of the related output.
- ※5) Manual Output Mode: OFF: Output by temperature / ON: Output by **nb** (FX3Q-RTD-R4)
- ※6) Manual Output Value Setup: It outputs continuously regardless setup temp. if manual output value is ON when manual output mode is ON. (FX3Q-RTD-R4)

Setting 2 Group Table

NO	DESCRIPTION	CODE	UNIT	STEP	MIN	MAX	DEFAULT	USER SETUP
500	Select Lock Function	LoC			OFF: Lock cancel LC1: Setting 1group LC2: Setting 1, 2 group lock LC3: Setting 1, 2group, temp. setup lock		OFF	
502	Max. Setup Value by User (※7)	USH	-	1	USL	800	800	
503	Min. Setup Value by User (※7)	USL	-	1	-19.9	USH	-19.9	
505	Decimal Point Display (※8)	dP			0.1 : 0.1	1 : 1	0.1	
506	Correct Temp. Sensor	Cor	K	0.1	-19.9	+19.9	0.0	
507	Sensor Input Filter (※9)	Sft	Sec.	0.1	0.2	10.0	0.5	
508	Sensor Value Display Cycle	Sdt	Sec.	0.1	0.0	5.0	0.1	
509	Setup Value Unification Mode (※10)	Sto	-		OFF: Individual Temp. setup On: Unifying Temp. setup		OFF	
510	Communication Address (FX3Q-RTD-R4)	ADR	-	1	0	128	1	
511	Communication Speed (FX3Q-RTD-R4)	bdr	-	1	0	3	1	
512	Analogue Trans. Output (20mA) (FX3Q-RTD-A1)	rth	°C	1	-200	800	400	
513	Analogue Trans. Output (4mA) (FX3Q-RTD-A1)	rtl	°C	1	-200	800	-100	

- ※7) User Setup Max./Min.: It inputs the range of temperature setup value.
- ※8) Decimal Point Display: In case of setting as '1', it displays the current value with cutting the decimal place.
- ※9) Sensor Input Filter Value: It avoids hunting by giving temperature measuring delay.
- ※10) Setup Value Unification Mode: In case of setting this function as ON, temperature setup value from output #1 to output #4 unifies as setup value of output #1.

Alarm Operation Group

AL1	<p>※ In case of setting deviation temp. as 1°C for AL1 (AL2)</p>	Deviation high limit alarm Output ON when PV value comparing with SV value has high limit deviation over alarm temp. setup value
AL2	<p>※ In case of setting deviation temp. as 1°C for AL1 (AL2)</p>	Deviation low limit alarm Output ON when PV value comparing with SV value has low limit deviation over alarm temp. setup value
AL3	<p>※ In case of setting deviation temp. as 10°C for AL1 (AL2)</p>	Deviation high, low limit alarm Output ON when PV value comparing with SV value has high, low limit deviation over alarm temp. setup value.
AL4	<p>※ In case of setting deviation temp. as 1°C for AL1 (AL2)</p>	Deviation high, Low limit reverse alarm Output OFF when PV value comparing with SV value has high, low limit deviation over alarm temp. setup value
ALS	<p>※ In case of setting alarm temp. as 11°C for AL1 (AL2)</p>	Absolute value high limit alarm Output ON when PV value comparing with SV & alarm temp. setup value is equal or higher
AL6	<p>※ In case of setting alarm temp. as 9°C for AL1 (AL2)</p>	Absolute value low limit alarm Output ON when PV value comparing with SV & alarm temp. setup value is equal or lower
SbA		Sensor open wire alarm Output ON when sensor is disconnected.

Alarm Option Group

CODE	동작 명칭	경보 옵션 동작 내용
ALa	General alarm	Standard alarm operation without option
ALb	Maintain alarm	Maintain output ON after alarm occurs
ALc	Standby alarm	No output at initial operation (until achieve the 1st setup value)
ALd	Maintain & standby alarm	Execute both ALb & ALC at the same time

Simple Trouble Check Point

In case of error occurring, the following messages are flickering at every 0.5 sec intervals.

oPn	In Case of Input Sensor Open Wire (Normal operation after sensor connecting)	LLL	Lower Sensor Input than Measuring Range
SHt	In Case of Sensor Short Circuit	HHH	Higher Sensor Input than Measuring Range (SH)

※ In case of the above-mentioned error, it will be normally operated with cancelling error status if the reason of error is solved.