

Multi-Function Temp Controller (FX3FS SERIES)



PreCaution for Use

1. This product may cause an electric shock in handling. Please do not attempt to open it with power turned on.
 2. This product should be installed in a place fixed secured by a rack or panel.
 3. This product can be used under the following environmental condition
 ① Indoor ② Pollution Degree 2 ③ At an altitude of 2000m or below ④ Installation Category II
 4. To turn on or turn off power supply for this product, please the circuit breaker or switch of a standard product of IEC 60947-1 or IEC 60947-3 product and install it within a close distance allowing convenient operation by user.
 5. Please be understood that if this product is dismantled or modified discretionary, after sales service will not be able to be provided.
 6. An output wire to be used for this product should be inflammable grade FV1 (V-1 grade or above), the thickness of the wire should be AWG No. 20 or above. (0.50mm²)
 7. In order to prevent it from an inductive noise, please maintain the high-voltage wire and power wire separated.
 8. Please avoid installing the product in a place where a strong magnetism, noise, severe vibration and impact exist.
 9. When extending the sensor wire, use a shield wire and do not extend it unnecessary long.
 10. The sensor wire and signal wire should be away from the power and load wires using conduits separately installed.
 11. Please avoid using the product near a device generating strong high frequency noise (high-frequency welding machine, high-frequency sewing machine, high-frequency radiotelegraph, high capacity SCR controller)
 12. Product's damages other than those described in the guarantee conditions provided by the manufacturer shall not be responsible by us.
 13. Please use with being attached to a dual safety device in case of using for controlling instruments which could be effective to human life or property (eg: controlling atomic energy, medical instruments, cars, trains, flights, burners, amusement instruments or safety machinery).
- ※ The Aforementioned precautions must be observed, and if you fail to do so, it may cause a product's breakdown.

Function & Features

Virtual Input Function :
 FX3S calculates and controls virtual current temperature by various calculation function with input from two temp sensors (T1,T2). Virtual current temperature can be selected as one of the following modes : T1, T2, T1+T2, average rate of T1 and T2, T1-T2, T2-T1

Operation Function when Sensor Error :
 It works by T2 temp sensor when T1 sensor error occurs. It enables ON/OFF output by operation period remembered 2 hours ago when there are errors in both temp sensors (User can set up the period.)

Basic Specification

모델명	FX3FS
Power	AC100-240V ~, 50/60Hz
Current	MAX 4VA
Connector	Screw Bolt Connector(1.5mm ² Wire is Possible)
Input / Output	Relay Output 1 Point (250Vac/16A) Temp. Sensor Input 2 Points
Operation	Temp. -10~50°C, Humidity Under 90%RH
Storage	Temp. -20~60°C, Humidity Under 90%RH
Range	Dotech Standard NTC Sensor DPR-TH1 5kΩ at 25°C, Limit:-50 ~ 105°C, Accuracy:±0.3°C at 25°C Dotech Standard NTC Sensor DPR-TH2 10kΩ at 25°C, Limit:-50 ~ 150°C, Accuracy:±1.5°C at 25°C

Order Information

FX3FS - 00 : Basic Model

※ 2 DPR-TH1-ET sensors are provided basically, and it is possible to purchase the required sensor separately.

Display Message

dEF Present temperature and *dEF* message display by turns at natural defrost.

Simple Trouble Check Point

In case of error occurring, the following messages are flickering at every 0.5 sec. intervals.

<i>SYS</i>	In Case of change of set value by an unknown case.
<i>oP1 oP2</i>	Input sensor open wire in T1 or T2 (Normal operation after sensor connecting)
<i>SH1 SH2</i>	Input sensor short circuit in T1 or T2
<i>LL1 LL2</i>	Lower sensor input than measuring range in T1 or T2
<i>HH1 HH2</i>	Higher sensor input than measuring range in T1 or T2
<i>RSF</i>	Errors occur in all of sensors controllable

※ In case of the above-mentioned error, it will be normally operated with cancelling error status if the reason of error is solved.

Connection Diagram

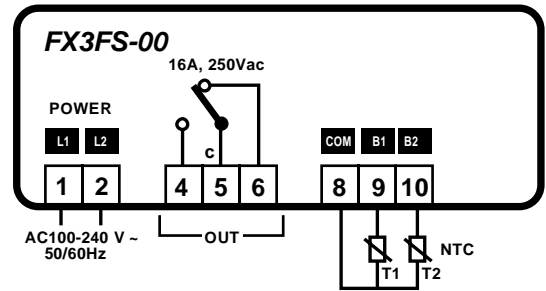

- OUT : Cooling/Heating ON/OFF Output
- T1 : Temp Sensor #1, T2 : Temp Sensor #2

Dimensions and Panel Cut-Out Form

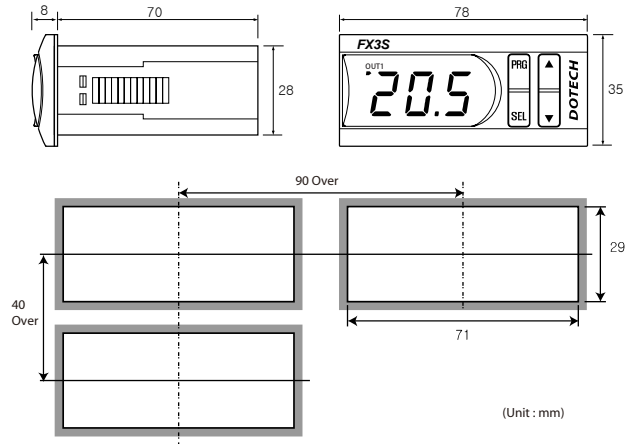

Constitution



Display Lamp

OUT1	Turn on when output #1 is ON (Flickering at standby)
Save	Storage data of 2 hours is made (Output pattern when sensor error occurs)
°C	Display temp. value
⚠	ON at trip, Flickering at alarm

Display Lamp

PRG	Use at program setup	▲	- Move between menus & Increase setup value - Display temp T1
SEL	Execute selected menu or Input setup value	▼	- Move between menus & Decrease setup value - Display temp T2
PRG	Initializing setup value	▼ (10 sec)	If pushing for 10 sec. at the same time, setup value is initialized
▲	Confirm current temp. decimal point	▲ (10 sec)	At the same time, it displays the 1st decimal place for the current temp. Delete storage data of 2 hours If press both buttons for 10 sec. when sensor error occurs.

Temperature Setting Group

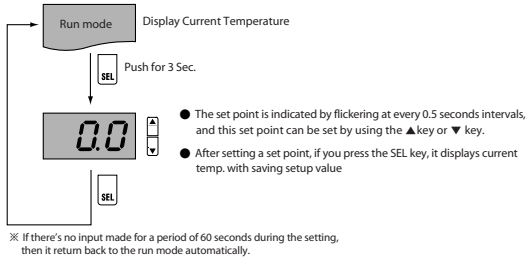

Setting 1 Group

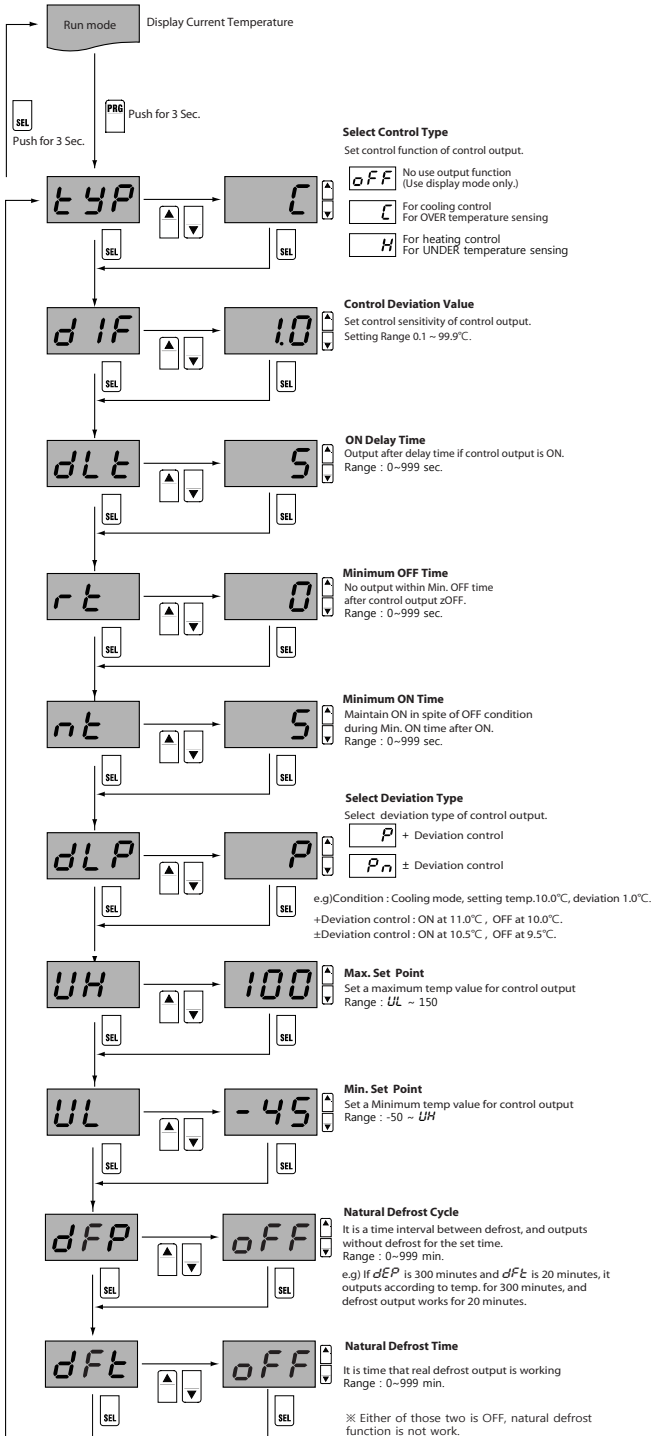

Setting 2 Group

